

Bezeichnung	01SMHF2-82J0		
Oxni Code	3AB	Servomotor	
Für Soforthilfe	info@oxni.ch +41 52 551 00 40	Für Reparaturen	Oxni GmbH Klosterstrasse 34 8406 Winterthur

Es müssen die Hinweise aus dem mitgelieferten Produktehandbuch beachtet werden!

Stecker	1 yTec	Stecker (drehbar, yTec)
Temperatursensor	KTY 84-130	
Bremse	keine	
Feedback	2-poliger Resolver	
Umgebung	-20..+40°C -1000 m.ü.M.	

Technische Daten

Stillstandsmoment	0.2 Nm	
Stillstandsstrom	0.76 A	
Nominal Moment	0.18 Nm	Aluminium 230x130x10mm
Nominal Geschwindigkeit	8000 rpm	
Nominal Leistung	150 W	
Nominal Spannung	230 VAC	
Spitzenstrom	2.3 A	
Spitzenmoment	0.68 Nm	
Maximale Spannung	480 VAC	
Maximale Geschwindigkeit	10'000 rpm	
Spannungskonstante	27 mV/min	
Wicklungswiderstand	34.5 Ω	
Wicklungsinduktivität	21 mH	
Rotor Trägheitsmoment	0.0294 kgcm ²	
Motorpole	6 -	

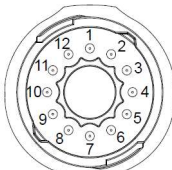

	1	SIN-	7	REF+	GEHÄUSE Schirm
	2	COS-	8	-	
	3	-	9	-	
	4	-	10	SIN+	
	5	REF-	11	COS+	
	6	-	12	-	

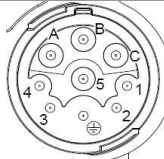
	A	U	1	-
	B	V	2	-
	C	W	3	Temperatur +
	PE	PE	4	Temperatur -
			5	-

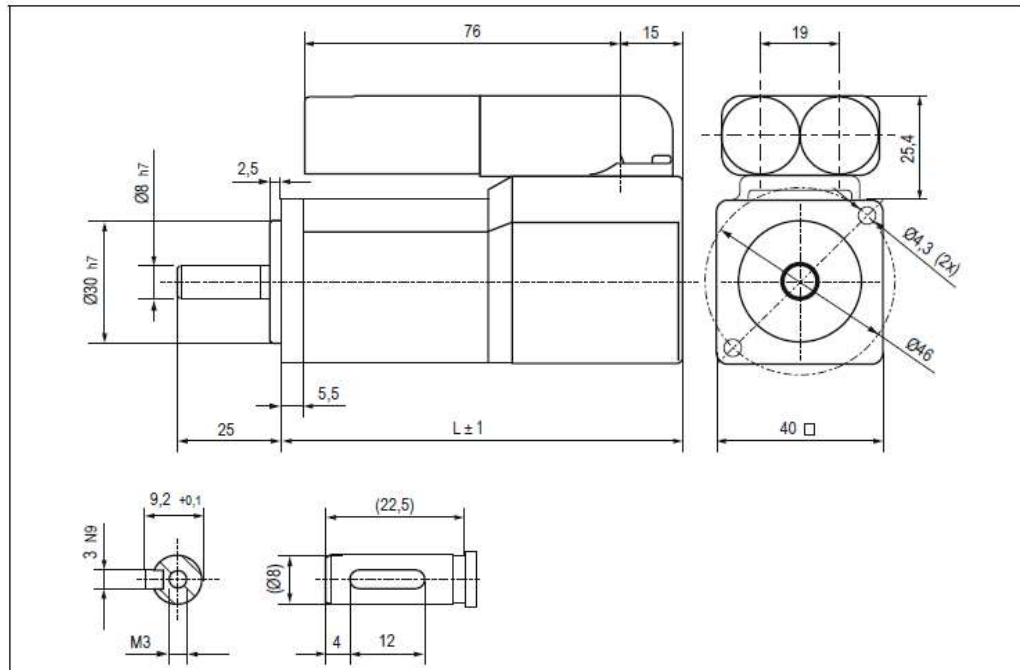

Motortyp	Bremse	L ohne Haltebremse	L mit Haltebremse
	01		97
02		117	149
03		137	169

Abbildung 12: Abmessungen Servomotore 0xSMHFx-xxxx

Motortyp	n _{max} / min-1	FR max / N	FR in Abhängigkeit von n					FA / N	FA max / N
			20 % * n _{max}	40 % * n _{max}	60 % * n _{max}	80 % * n _{max}	100 % * n _{max}		
			01SMHF	8000	320	168.7	133.9		

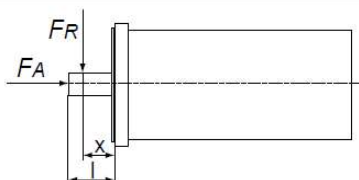
F _A	Axialkraft	
F _R	Radialkraft	
X	Länge der Läuferachse bis zum Mittelpunkt der wirkenden Radialkraft	
l	Länge der Läuferachse	

